

Applied Mouldings

Appendix C

Applied Mouldings

Marshfield DoorSystems offers three standard applied mouldings. They are:

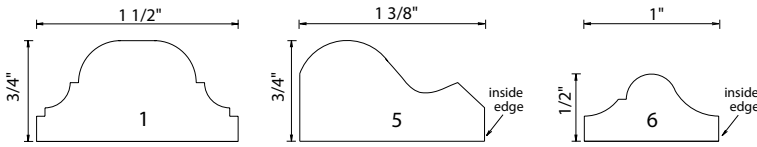

Profile 5 is the applied moulding that will be used on the Marshfield DoorSystems Styled™ Door unless specified otherwise. Additional custom mouldings are available to suit any project. (An upcharge for custom moulding will apply and additional lead-time is required.) Mouldings are available in most species of lumber.

- Unfinished and primed doors will not have nail holes filled.
- Factory finished doors with applied mouldings will have nail holes filled.

Applied Mouldings for Fire Doors (2)

	UL 20-minute	UL 45-90-minute	ITS-WH 20-minute	ITS-WH 45-90-minute
Maximum Size	No Limit	1-1/2" x 3/4"	No Limit	1-1/2" x 3/4"
Application Method	Glue	Glue	Glue	Glue
Minimum Distance between Parallel Moulding Pieces	No Limit	3"	No Limit	3"
Minimum Distance between Lite and Applied Moulding	No Limit	No Limit	3-1/2"	3-1/2"
Minimum Distance between Door Edge and Moulding (1)	1"	1"	1"	1"

(1) Moulding must not interfere with the operation of the door, hardware or accessories.

(2) Installation of applied moulding on doors with either UL or ITS-WH labels must be done by Marshfield DoorSystems or a licensed machiner.

Dutch Shelves

Appendix D

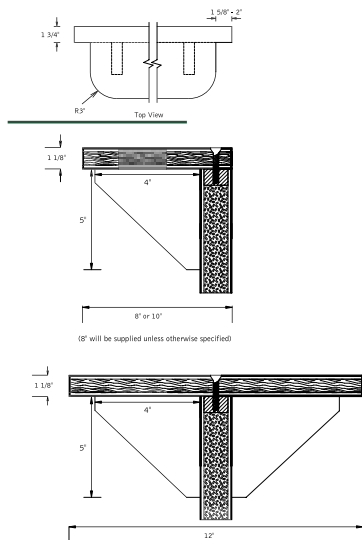

Dutch Shelves

- Shelves are manufactured at the factory and include wood brackets for jobsite installation. Plastic for shelves is shipped loose for jobsite application.
- Use #12 x 2" full threaded screws. Use one screw for each foot or fractional foot of shelf width to attach shelf to top of bottom leaf. Two screws minimum for any shelf.
- Brackets may be attached with any combination of screws, nails and/or glue.
- On 20-minute dutch doors, a 1/16" x 1/2" intumescent strip is factory installed in the bottom rail of the top leaf.
- Shelf ends are trimmed to length and beveled as ordered and dimensions will vary 1-5/8" - 2".

Packaging

Doors are palletized in quantities determined by the number ordered and size. Stretch wrapping, sheet corrugated cardboard and banding are combined to give you superior packaging to protect your doors. For an additional cost, doors may be individually protected with polywrap or cardboard cartons and specially packaged for jobsite delivery and coordination. When delivered by common carrier, doors are packaged using specially reinforced materials.

Bottom board palletizing is available. When selecting the bottom board palletizing service, Marshfield DoorSystems will add a 7/16" Oriented Strand Board (OSB) to the bottom of the door pallet, offering an extra layer of protection.

Note: Marshfield DoorSystems doors are manufactured per the standards listed on this page. Specifications are subject to change without notice.