

Flush Veneer Clad Lite Bead Field Installation Instructions

Warning: Doors that are installed without 8" metal clips do not meet fire approvals and are not covered under Marshfield DoorSystems warranty.

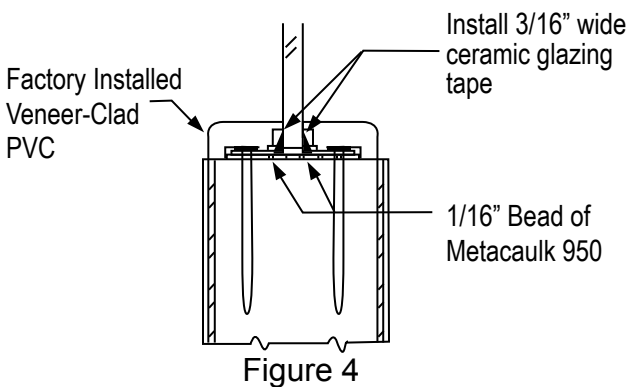
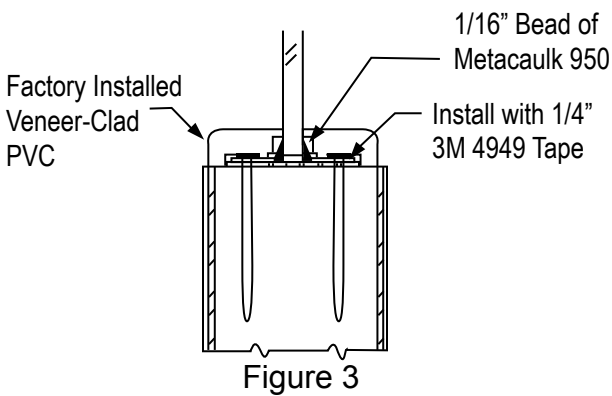
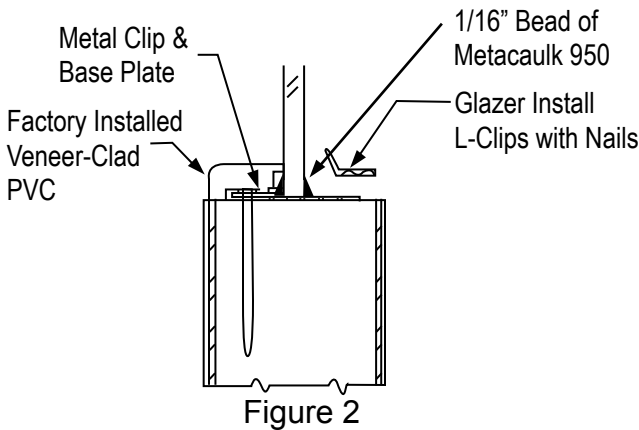
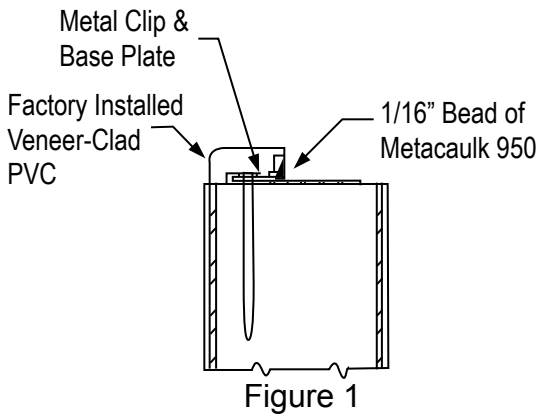

1. Remove packaged prefit pieces of moulding and clips from the lite opening. (Caution: Overflexing the moulding may cause the veneer to crack).

2. For openings over 100 square inches, apply a 1/16" bead of Metacaulk 950 on the factory installed metal clip (see Figure 1).

For 1/4" Thick Glazing:

3. Insert 1/4" ITS-WH or UL listed glass. Apply another bead of 1/16" Metacaulk 950 around the perimeter of the glass (See Figure 2).

For 3/16" Thick Glazing:

On both sides, adhere the 3/16" wide piece of white ceramic glazing tape around the outside perimeter of the ITS-WH or UL listed glazing. Insert the glass. Apply another bead of Metacaulk 950 around the perimeter of the glass placing it directly on the ceramic glazing (See Figure 4).

4. Using 2" long nails, install the clips using the spacing shown (see below), and set the nails flush. Staggered spacing of clips is necessary to keep the glass from breaking.

Caution: Do NOT use a power nailer!

→ | | ← 1/8"

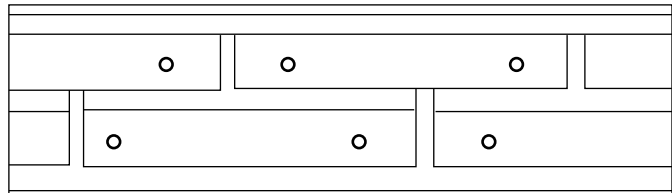

Factory Installed T-Clips

5. Peel backing from the exposed side of the tape on the bottom of the moulding. Place moulding over clips and press firmly to adhere entire surface of tape to metal clips (See figure 4).